

車削刀具系列

Turning Tools Series

泛用鋼材 $\leq 50\text{HRC}$

不銹鋼













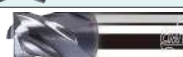



鋁合金 / 銅合金

鑄鐵

For general steel ($\leq 50\text{HRC}$), stainless steel, cast iron and aluminum/copper alloy machining.

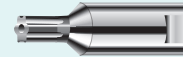

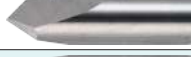
產品選擇表 Product Selection Table

刀型 Type	刃數 Flute	型號 Model Number	產品類別 Product Classification	形狀 Appearance	尺寸 Size	頁數 Page
車床刀具系列 Carbide Tools For Automatic Lathe						
平刀 Square	二刃 2 Flutes	CLES20000A	小柄短刃型 -With Small Shank		Ø2 ~ Ø12	420
	三刃 3 Flutes	CLES30000A	小柄短刃型 -With Small Shank		Ø2 ~ Ø12	420
	四刃 4 Flutes	CLES40000A	小柄短刃型 -With Small Shank		Ø4 ~ Ø16	421
	六刃 6 Flutes	CLES60000A	小柄短刃型 -With Small Shank		Ø6 ~ Ø16	421
端面槽刀 Face Grooving	單刃 1 Flute	CLF000000A		Ø1.8 ~ Ø2.8	422	
內孔端面槽刀 Internal Face Grooving	單刃 1 Flute	CLFI000000A		Ø1.8 ~ Ø2.8	423	
內孔掃刀 Internal Copy Turning	單刃 1 Flute	CLB00000000A	7°		Ø0.8 ~ Ø3.8	424
			15°		Ø0.8 ~ Ø3.8	425
內孔槽刀 Internal Grooving	單刃 1 Flute	CLG000000A		Ø1.7 ~ Ø3.8	426	
內孔圓鼻槽刀 Internal Radius Grooving	單刃 1 Flute	CLRG000000A		Ø1.7 ~ Ø2.8	427	
內孔牙刀 Internal Threading	單刃 1 Flute	CLT0000000A	螺紋型-ISO規格 -Internal-ISO		Ø1.4 ~ Ø2.8	428
		CLT0000000000A	螺紋型-ISO規格 -Internal-ISO		Ø1.0 ~ Ø2.6	428
沖頭 Punch		CLPH00000	六角型 -Hexagon		T1.5 ~ T6.0	429
		CLPS00000	梅花型 -Six Lobe		T6 ~ T30	429
雕刻剖半圓棒 Engraving Blanks Precision Ground	單刃 1 Flute	CLEBS0000	短刃型 -Short Flute		Ø2 ~ Ø12	430
	單刃 1 Flute	CLEBL0000	長刃型 -Long Flute		Ø2 ~ Ø12	430
扁型定位鑽 Flat Point Set	二刃 2 Flutes	CLPR00000	右刃型 -Right Hand Cutting		Ø3 ~ Ø6	431
	二刃 2 Flutes	CLPL00000	左刃型 -Left Hand Cutting		Ø6	431
T型刀 Slot Cutter		CLFS00000000	直刃型 -Flat Flute		Ø15 ~ Ø30	432

碳素鋼 Carbon Steels (<20HRC)	合金鋼 Alloy Steels (20~30HRC)	合金鋼 Alloy Steels (30~45HRC)	調質鋼 Hardened Steels (45~55HRC)	調質鋼 Hardened Steels (55~65HRC)	不銹鋼 Stainless Steels	鑄鐵 Cast Iron	鋁合金 Aluminum Alloys	銅 Copper	非金屬 Non-metal	高溫合金 High-Temp Alloys	冷卻方式推薦 Suitable Coolant	加工型態 Type of Finishing			
												A	B	C	D
											乾式 / 濕式 (Dry / Wet)	—			
			—	—			—	—	—	—	乾式 / 濕式 (Dry / Wet)	—			
			—	—			—	—	—	—	乾式 / 濕式 (Dry / Wet)				—
			—	—			—	—	—	—	乾式 / 濕式 (Dry / Wet)				—
			—	—					—	—	濕式(Wet)				
			—	—					—	—	濕式(Wet)				
			—	—					—	—	濕式(Wet)				
			—	—					—	—	濕式(Wet)				
			—	—					—	—	濕式(Wet)				
			—	—					—	—	濕式(Wet)				
			—	—					—	—	濕式(Wet)				
		—	—	—	—	—			—	—	濕式(Wet)				
		—	—	—	—	—			—	—	濕式(Wet)				
		—	—	—	—	—			—	—	濕式(Wet)				
		—	—	—					—	—	濕式(Wet)				

S220 鎢鋼平銑刀- 小柄短刃型- 2刃

S220 MICRO GRAIN CARBIDE END MILLS- Square Type- with small shank For Lathe- 2F

· CLES20000A



刃徑 d	公差 Tolerance
$\phi < 3$	0 ~ -0.02
$3 \leq \phi \leq 10$	-0.01 ~ -0.03
$10 < \phi$	-0.01 ~ -0.04

超精銑 Bright Finishing	—
精銑 Finishing	○
中銑 Semi Finishing	◎
粗銑 Roughing	○

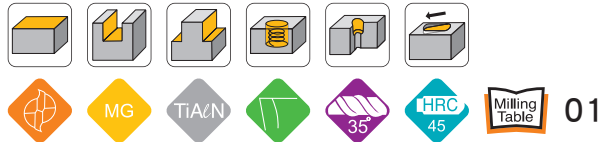

刃徑 d	刃長 L1	全長 L	柄徑 D	刃數 F	白刀訂購編號 Uncoated Order No.	鍍膜訂購編號 Coated Order No.
2.0	2	40	6	2	CLES20200	CLES20200A
3.0	3	40	6	2	CLES20300	CLES20300A
4.0	4	40	6	2	CLES20400	CLES20400A
5.0	5	40	6	2	CLES20500	CLES20500A
6.0	6	40	6	2	CLES20600	CLES20600A
7.0	7	40	6	2	CLES20700	CLES20700A
8.0	8	40	6	2	CLES20800	CLES20800A
9.0	9	40	6	2	CLES20900	CLES20900A
10.0	10	40	6	2	CLES21000	CLES21000A
12.0	12	40	10	2	CLES21200	CLES21200A

S220 鎢鋼平銑刀- 小柄短刃型- 3刃

S220 MICRO GRAIN CARBIDE END MILLS- Square Type- with small shank For Lathe- 3F

· CLES30000A

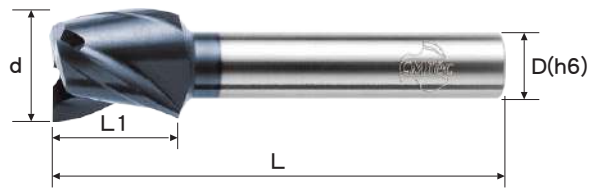

刃徑 d	公差 Tolerance
$\phi < 3$	0 ~ -0.02
$3 \leq \phi \leq 10$	-0.01 ~ -0.03
$10 < \phi$	-0.01 ~ -0.04

超精銑 Bright Finishing	—
精銑 Finishing	◎
中銑 Semi Finishing	◎
粗銑 Roughing	○

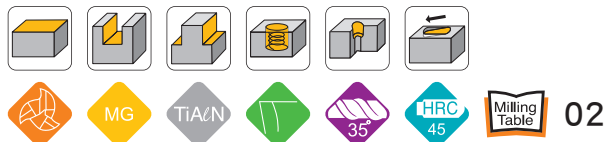

刃徑 d	刃長 L1	全長 L	柄徑 D	刃數 F	白刀訂購編號 Uncoated Order No.	鍍膜訂購編號 Coated Order No.
2.0	2	40	6	3	CLES30200	CLES30200A
3.0	3	40	6	3	CLES30300	CLES30300A
4.0	4	40	6	3	CLES30400	CLES30400A
5.0	5	40	6	3	CLES30500	CLES30500A
6.0	6	40	6	3	CLES30600	CLES30600A
7.0	7	40	6	3	CLES30700	CLES30700A
8.0	8	40	6	3	CLES30800	CLES30800A
9.0	9	40	6	3	CLES30900	CLES30900A
10.0	10	40	6	3	CLES31000	CLES31000A
12.0	12	40	10	3	CLES31200	CLES31200A

S220 鎢鋼平銑刀- 小柄短刃型- 4刃

S220 MICRO GRAIN CARBIDE END MILLS- Square Type- with small shank For Lathe- 4F

· CLES40000A

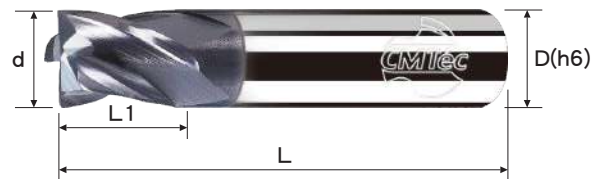

刃徑 d	公差 Tolerance
$\phi < 3$	0 ~ -0.02
$3 \leq \phi \leq 10$	-0.01 ~ -0.03
$10 < \phi$	-0.01 ~ -0.04

超精銑 Bright Finishing	<input type="radio"/>
精銑 Finishing	<input checked="" type="radio"/>
中銑 Semi Finishing	<input type="radio"/>
粗銑 Roughing	<input type="radio"/>

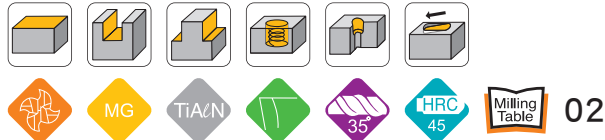

刃徑 d	刃長 L1	全長 L	柄徑 D	刃數 F	白刀訂購編號 Uncoated Order No.	鍍膜訂購編號 Coated Order No.
4.0	4	40	6	4	CLES40400	CLES40400A
5.0	5	40	6	4	CLES40500	CLES40500A
6.0	6	40	6	4	CLES40600	CLES40600A
7.0	7	40	6	4	CLES40700	CLES40700A
8.0	8	40	6	4	CLES40800	CLES40800A
8.0	8	40	8	4	CLES4080008	CLES4080008A
10.0	10	40	6	4	CLES41000	CLES41000A
10.0	10	40	10	4	CLES4100010	CLES4100010A
12.0	12	40	10	4	CLES41200	CLES41200A
16.0	16	40	10	4	CLES41600	CLES41600A

S220 鎢鋼平銑刀- 小柄短刃型- 6刃

S220 MICRO GRAIN CARBIDE END MILLS- Square Type- with small shank For Lathe- 6F

· CLES60000A



刃徑 d	公差 Tolerance
$\phi < 3$	0 ~ -0.03
$3 \leq \phi \leq 10$	-0.01 ~ -0.04
$10 < \phi$	-0.01 ~ -0.05

超精銑 Bright Finishing	<input type="radio"/>
精銑 Finishing	<input checked="" type="radio"/>
中銑 Semi Finishing	<input type="radio"/>
粗銑 Roughing	<input type="radio"/>

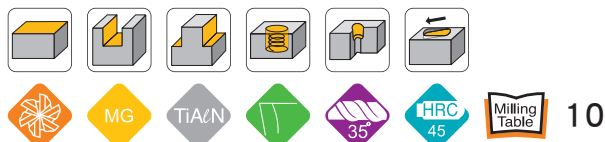

刃徑 d	刃長 L1	全長 L	柄徑 D	刃數 F	白刀訂購編號 Uncoated Order No.	鍍膜訂購編號 Coated Order No.
6.0	6	40	6	6	CLES60600	CLES60600A
7.0	7	40	6	6	CLES60700	CLES60700A
8.0	8	40	6	6	CLES60800	CLES60800A
9.0	9	40	6	6	CLES60900	CLES60900A
10.0	10	40	6	6	CLES61000	CLES61000A
12.0	12	40	10	6	CLES61200	CLES61200A
16.0	16	40	10	6	CLES61600	CLES61600A

鎢鋼端面槽刀

CARBIDE FACE- Grooving

· CLF000000A

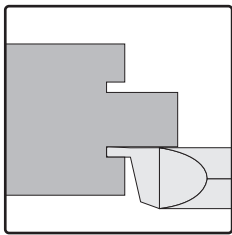
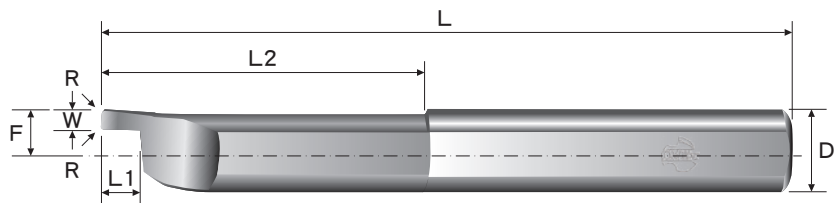

F	W	R	L1	L2	L	D	最小車徑 Min. Bore Dia.	鍍膜訂購編號 Coated Order No.
1.8	0.75	0.1	1.2	15	50	4	4	CLF151807A
1.8	1.00	0.1	1.5	15	50	4	4	CLF151810A
1.8	1.50	0.1	2.8	15	50	4	4	CLF151815A
2.3	0.75	0.1	1.2	22	50	5	5	CLF222307A
2.3	1.00	0.1	1.5	22	50	5	5	CLF222310A
2.3	1.50	0.1	2.5	22	50	5	5	CLF222315A
2.3	2.00	0.1	3.8	22	50	5	5	CLF222320A
2.8	1.00	0.1	1.5	22	50	6	6	CLF222810A
2.8	1.50	0.1	2.5	22	50	6	6	CLF222815A
2.8	2.00	0.1	3.0	22	50	6	6	CLF222820A
2.8	2.50	0.1	4.8	22	50	6	6	CLF222825A
2.8	3.00	0.1	6.0	30	60	6	6	CLF302830A

→ 切削條件表
Cutting Condition P.582

TURNING Turning Tools 車削刀具

鎢鋼內孔端面槽刀

CARBIDE INTERNAL - Face Grooving

· **CLFI000000A**

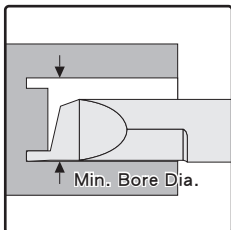
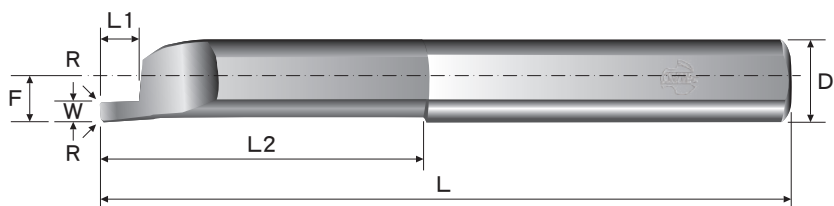

87

F	W	R	L1	L2	L	D	最小車徑 Min. Bore Dia.	鍍膜訂購編號 Coated Order No.
1.8	0.75	0.1	1.2	15	50	4	4	CLFI151807A
1.8	1.00	0.1	1.5	15	50	4	4	CLFI151810A
1.8	1.50	0.1	2.8	15	50	4	4	CLFI151815A
2.3	0.75	0.1	1.2	22	50	5	5	CLFI222307A
2.3	1.00	0.1	1.5	22	50	5	5	CLFI222310A
2.3	1.50	0.1	2.5	22	50	5	5	CLFI222315A
2.3	2.00	0.1	3.8	22	50	5	5	CLFI222320A
2.8	1.00	0.1	1.5	22	50	6	6	CLFI222810A
2.8	1.50	0.1	2.5	22	50	6	6	CLFI222815A
2.8	2.00	0.1	3.0	22	50	6	6	CLFI222820A
2.8	2.50	0.1	4.8	22	50	6	6	CLFI222825A
2.8	3.00	0.1	6.0	30	60	6	6	CLFI302830A

鎢鋼內孔掃刀

CARBIDE INTERNAL - Copy Turning

· **CLB00000000A**

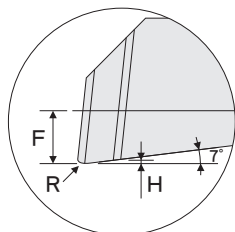
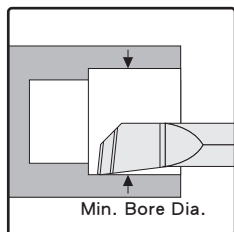
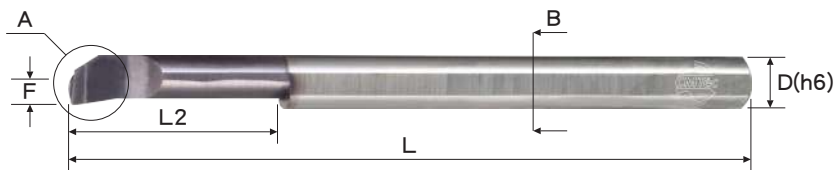

細部放大圖
Detail **A**

細部放大圖
Detail **B**



59

F	L2	L	R	D	H	D1	最小車徑 Min. Bore Dia.	鍍膜訂購編號 Coated Order No.
0.8	5	39	0.15	3	0.1	2.85	2.4	CLB05081507A
0.8	10	39	0.15	3	0.1	2.85	2.4	CLB10081507A
1.3	10	39	0.05	3	0.2	2.85	3.1	CLB10130507A
1.3	15	39	0.05	3	0.2	2.85	3.1	CLB15130507A
1.3	15	39	0.10	3	0.2	2.85	3.1	CLB15131007A
1.3	10	39	0.20	3	0.2	2.85	3.1	CLB10132007A
1.3	15	39	0.20	3	0.2	2.85	3.1	CLB15132007A
1.7	10	50	0.10	4	0.2	3.80	4.1	CLB10171007A
1.7	15	50	0.10	4	0.2	3.80	4.1	CLB15171007A
1.7	22	50	0.10	4	0.2	3.80	4.1	CLB22171007A
1.7	10	50	0.20	4	0.2	3.80	4.1	CLB10172007A
1.7	15	50	0.20	4	0.2	3.80	4.1	CLB15172007A
1.7	22	50	0.20	4	0.2	3.80	4.1	CLB22172007A
2.1	15	50	0.10	5	0.3	4.75	5.1	CLB15211007A
2.1	22	50	0.10	5	0.3	4.75	5.1	CLB22211007A
2.1	30	75	0.10	5	0.3	4.75	5.1	CLB30211007A
2.1	15	50	0.20	5	0.3	4.75	5.1	CLB15212007A
2.1	22	50	0.20	5	0.3	4.75	5.1	CLB22212007A
2.1	30	75	0.20	5	0.3	4.75	5.1	CLB30212007A
2.8	15	50	0.05	6	0.3	5.70	6.1	CLB15280507A
2.8	15	50	0.10	6	0.3	5.70	6.1	CLB15281007A
2.8	15	50	0.20	6	0.3	5.70	6.1	CLB15282007A
2.8	22	50	0.20	6	0.3	5.70	6.1	CLB22282007A
2.8	30	63	0.20	6	0.3	5.70	6.1	CLB30282007A
3.8	15	63	0.20	8	0.5	7.60	8.1	CLB15382007A
3.8	22	63	0.20	8	0.5	7.60	8.1	CLB22382007A

→ 切削條件表
Cutting Condition **P.564**

鎢鋼內孔掃刀

CARBIDE INTERNAL - Copy Turning

· **CLB00000000A**

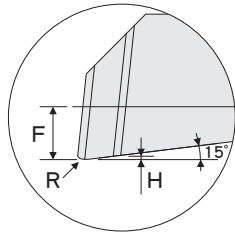
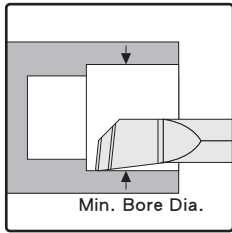
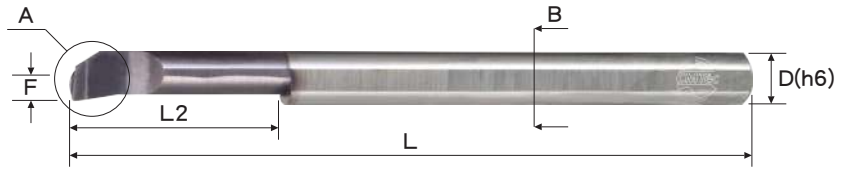

細部放大圖
Detail **A**

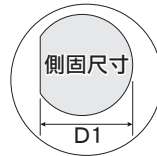

細部放大圖
Detail **B**



59

F	L2	L	R	D	H	D1	最小車徑 Min. Bore Dia.	鍍膜訂購編號 Coated Order No.
0.8	5	39	0.15	3	0.31	2.85	2.4	CLB05081515A
0.8	10	39	0.15	3	0.31	2.85	2.4	CLB10081515A
1.3	10	39	0.05	3	0.44	2.85	3.1	CLB10130515A
1.3	15	39	0.05	3	0.44	2.85	3.1	CLB15130515A
1.3	10	39	0.20	3	0.44	2.85	3.1	CLB10132015A
1.3	15	39	0.20	3	0.44	2.85	3.1	CLB15132015A
1.7	10	50	0.20	4	0.55	3.80	4.1	CLB10172015A
1.7	15	50	0.20	4	0.55	3.80	4.1	CLB15172015A
2.1	15	50	0.20	5	0.66	4.75	5.1	CLB15212015A
2.1	22	50	0.20	5	0.66	4.75	5.1	CLB22212015A
2.8	15	50	0.20	6	0.85	5.70	6.1	CLB15282015A
2.8	22	50	0.20	6	0.85	5.70	6.1	CLB22282015A
3.8	15	63	0.20	8	1.11	7.60	8.1	CLB15382015A
3.8	22	63	0.20	8	1.11	7.60	8.1	CLB22382015A

→ 切削條件表
Cutting Condition **P.564**

鎢鋼內孔槽刀

CARBIDE INTERNAL-Grooving

· CLG000000A

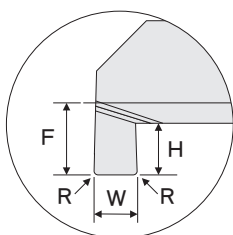
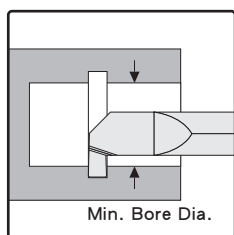

細部放大圖
Detail A



細部放大圖
Detail B



59

F	L2	L	W	R	D	H	D1	最小車徑 Min. Bore Dia.	鍍膜訂購編號 Coated Order No.
1.7	10	50	1.0	0.1	4	1.0	3.80	4.1	CLG101710A
1.7	10	50	1.5	0.1	4	1.0	3.80	4.1	CLG101715A
2.3	10	50	1.0	0.1	5	1.2	4.75	5.1	CLG102310A
2.3	10	50	1.5	0.1	5	1.2	4.75	5.1	CLG102315A
2.3	10	50	2.0	0.1	5	1.2	4.75	5.1	CLG102320A
2.8	20	50	1.0	0.1	6	1.4	5.70	6.1	CLG202810A
2.8	20	50	1.5	0.1	6	1.4	5.70	6.1	CLG202815A
2.8	20	50	2.0	0.1	6	1.4	5.70	6.1	CLG202820A
3.8	20	50	1.0	0.1	8	1.6	7.60	8.1	CLG203810A
3.8	20	50	1.5	0.1	8	1.6	7.60	8.1	CLG203815A
3.8	20	50	2.0	0.1	8	1.6	7.60	8.1	CLG203820A

TURNING Turning Tools

車削刀具

鎢鋼內孔外圓槽刀

CARBIDE INTERNAL - Full Radius Grooving

· **CLRG000000A**

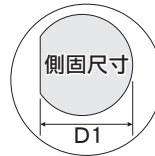
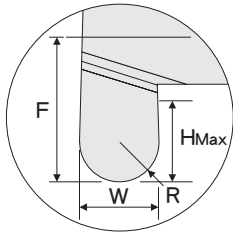
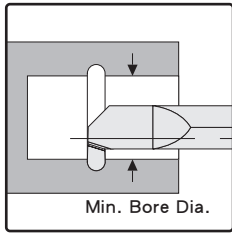
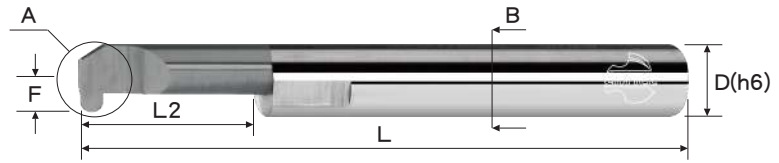

59

F	L2	L	R	W	D	H	D1	最小車徑 Min. Bore Dia.	鍍膜訂購編號 Coated Order No.
1.7	10	50	0.50	1.0	4	1.0	3.80	4.1	CLRG101710A
1.7	10	50	0.75	1.5	4	1.0	3.80	4.1	CLRG101715A
2.3	15	50	0.50	1.0	5	1.2	4.75	5.1	CLRG152310A
2.3	15	50	0.75	1.5	5	1.2	4.75	5.1	CLRG152315A
2.3	15	50	1.00	2.0	5	1.2	4.75	5.1	CLRG152320A
2.8	15	50	0.50	1.0	6	1.6	5.70	6.1	CLRG152810A
2.8	15	50	0.75	1.5	6	1.6	5.70	6.1	CLRG152815A
2.8	15	50	1.00	2.0	6	1.6	5.70	6.1	CLRG152820A

→ 切削條件表
Cutting Condition P.564

TURNING Turning Tools 車削刀具

鎢鋼內孔牙刀- 螺距固定型- ISO 60°

CARBIDE INTERNAL- Thread ISO Metric 60°

· CLT00000000A

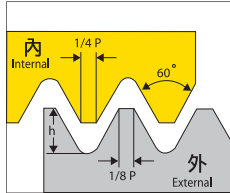

Tolerance class(公差)
6g / 6H

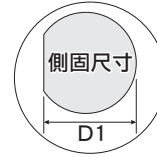
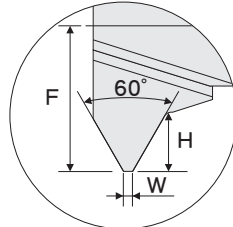
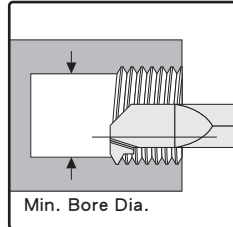

細部放大圖 B
Detail

細部放大圖 A
Detail



59

F	螺距 Pitch	L2	W	L	D	H	D1	最小車徑 Min. Bore Dia.	鍍膜訂購編號 Coated Order No.
1.4	0.50	10	0.062	39	3	0.33	2.85	3.2	CLT1014050A
1.4	0.70	10	0.087	39	3	0.46	2.85	3.2	CLT1014070A
1.4	0.75	10	0.093	39	3	0.49	2.85	3.2	CLT1014075A
1.8	0.50	10	0.062	50	4	0.33	3.80	4.1	CLT1018050A
1.8	0.75	10	0.093	50	4	0.49	3.80	4.1	CLT1018075A
1.8	0.80	10	0.100	50	4	0.52	3.80	4.1	CLT1018080A
2.2	1.00	10	0.125	50	5	0.65	4.75	4.9	CLT1022100A
2.6	0.50	15	0.062	50	6	0.33	5.70	5.9	CLT1526050A
2.6	0.75	15	0.093	50	6	0.49	5.70	5.9	CLT1526075A
2.6	1.00	15	0.125	50	6	0.65	5.70	5.9	CLT1526100A
2.8	1.25	22	0.156	50	6	0.81	5.70	6.1	CLT2228125A

鎢鋼內孔牙刀- 螺距泛用型- ISO 60°

CARBIDE INTERNAL MULTIPURPOSE- Thread ISO Metric 60°

· CLT000000000000A

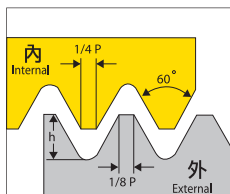
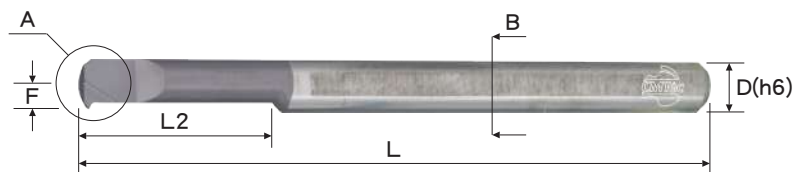

Tolerance class(公差)
6g / 6H

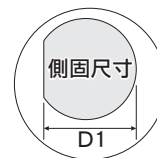
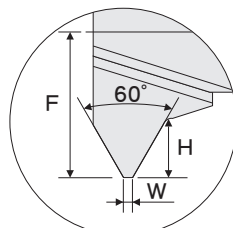
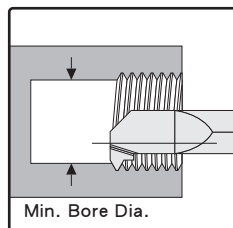

細部放大圖 B
Detail

細部放大圖 A
Detail



59

F	螺距 Pitch	L2	W	L	D	H	D1	最小車徑 Min. Bore Dia.	鍍膜訂購編號 Coated Order No.
1.0	0.45 ~ 0.70	8	0.056	39	3	0.45	2.85	2.6	CLT0810045070A
1.4	0.70 ~ 1.00	15	0.087	39	3	0.65	2.85	3.2	CLT1514070100A
1.8	0.80 ~ 1.00	15	0.100	50	4	0.65	3.80	4.1	CLT1518080100A
2.3	1.00 ~ 1.25	15	0.125	50	5	0.81	4.75	5.1	CLT1523100125A
2.6	1.00 ~ 1.50	15	0.125	50	6	0.97	5.70	6.0	CLT1526100150A

鎢鋼沖頭- 六角型

CARBIDE PUNCH- Hexagon

· CLPH00000

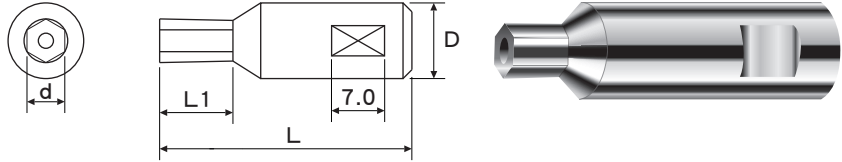

刃徑 d	公差 Tolerance
φ	±0.01

※ 特殊尺寸依需求生產。
Special size is on request.

規格 Drive Size	刃徑 d	刃長 L1	全長 L	柄徑 D	訂購編號 Order No.
T1.5	1.538	2.5	28	8	CLPH01508
T2	2.038	3.0	28	8	CLPH02008
T2.5	2.553	4.0	28	8	CLPH02508
T3	3.071	4.5	28	8	CLPH03008
T4	4.071	6.0	28	8	CLPH04008
T5	5.086	6.0	28	8	CLPH05008
T6	6.086	6.0	28	8	CLPH06008

鎢鋼沖頭- 梅花型

CARBIDE PUNCH- Six Lobe

· CLPS00000

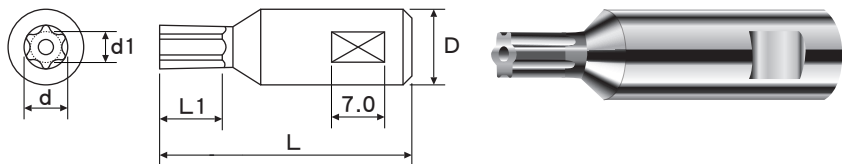

※ 特殊尺寸依需求生產。
Special size is on request.

規格 Drive Size	刃徑 d	內切圓 d1	刃長 L1	全長 L	柄徑 D	訂購編號 Order No.
T6	1.75	1.27	2.5	28	8	CLPS06008
T8	2.40	1.75	3.6	28	8	CLPS08008
T10	2.80	2.05	4.1	28	8	CLPS10008
T15	3.35	2.40	4.3	28	8	CLPS15008
T20	3.95	2.85	4.6	28	8	CLPS20008
T25	4.50	3.25	5.0	28	8	CLPS25008
T30	5.60	4.05	5.5	28	8	CLPS30008

鎢鋼雕刻剖半圓棒- 短刃型

CARBIDE ENGRAVING BLANKS PRECISION GROUND- Short Flute

· **CLEBS0000**

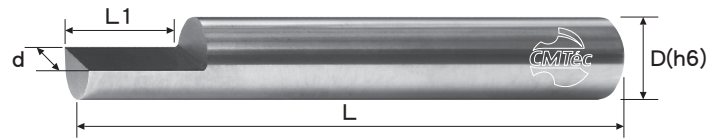

刃徑 d	刃長 L1	全長 L	柄徑 D	訂購編號 Order No.
2.0	3	40	2.0	CLEBS0200
2.5	4	40	2.5	CLEBS0250
3.0	5	40	3.0	CLEBS0300
3.5	6	50	3.5	CLEBS0350
4.0	6	50	4.0	CLEBS0400
4.5	8	50	4.5	CLEBS0450
5.0	8	50	5.0	CLEBS0500
6.0	9	50	6.0	CLEBS0600
7.0	10	50	7.0	CLEBS0700
8.0	12	60	8.0	CLEBS0800
10.0	15	75	10.0	CLEBS1000
12.0	18	75	12.0	CLEBS1200

鎢鋼雕刻剖半圓棒- 長刃型

CARBIDE ENGRAVING BLANKS PRECISION GROUND- Long Flute

· **CLEBL0000**

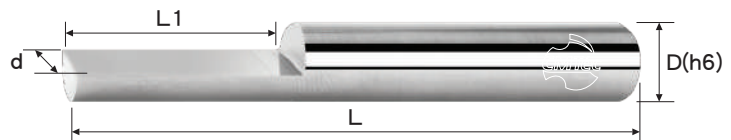

刃徑 d	刃長 L1	全長 L	柄徑 D	訂購編號 Order No.
2.0	6	40	2	CLEBL0200
3.0	9	40	3	CLEBL0300
4.0	12	50	4	CLEBL0400
5.0	15	50	5	CLEBL0500
6.0	18	50	6	CLEBL0600
7.0	21	50	7	CLEBL0700
8.0	24	60	8	CLEBL0800
10.0	30	75	10	CLEBL1000
12.0	36	75	12	CLEBL1200

鎢鋼扁型定位鑽- 右刃- 2刃

CARBIDE FLAT POINT SET- Right Hand Cutting- 2F

· CLPR00000



※ 加工範圍：軟材質
For soft material.

刃徑 d	尖端夾角 ε°	全長 L	柄徑 D	訂購編號 Order No.
3	60°	50	3	CLPR03060
4	60°	50	4	CLPR04060
5	60°	50	5	CLPR05060
6	60°	50	6	CLPR06060
3	90°	50	3	CLPR03090
4	90°	50	4	CLPR04090
5	90°	50	5	CLPR05090
6	90°	50	6	CLPR06090
3	120°	50	3	CLPR030C0
4	120°	50	4	CLPR040C0
5	120°	50	5	CLPR050C0
6	120°	50	6	CLPR060C0

鎢鋼扁型定位鑽- 左刃- 2刃

CARBIDE FLAT POINT SET- Left Hand Cutting- 2F

· CLPL00000



※ 加工範圍：軟材質
For soft material.

刃徑 d	尖端夾角 ε°	全長 L	柄徑 D	訂購編號 Order No.
6	60°	25	6	CLPL06060
6	80°	25	6	CLPL06080
6	90°	25	6	CLPL06090
6	100°	25	6	CLPL060A0
6	120°	25	6	CLPL060C0

鎢鋼T型刀- 直刃

CARBIDE T-SLOT END MILLS- Flat Flute

· CLFS00000000

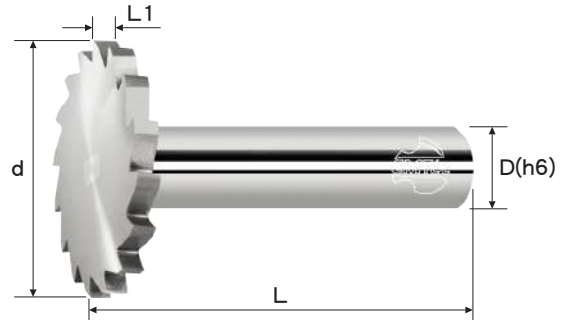

※ 柄部為焊接設計。
It's brazed shank.

刃徑 d	刃長 L1	全長 L	柄徑 D	刃數 F	訂購編號 Order No.	
15	1.0	50	7	16	CLFS1500100716	
15	1.5	50	7	16	CLFS1500150716	
15	2.0	50	7	16	CLFS1500200716	
15	2.5	50	7	16	CLFS1500250716	
15	3.0	50	7	16	CLFS1500300716	
20	1.0	50	7/10	16	CLFS2000100716	CLFS2000101016
20	1.5	50	7/10	16	CLFS2000150716	CLFS2000151016
20	2.0	50	7/10	16	CLFS2000200716	CLFS2000201016
20	2.5	50	7/10	16	CLFS2000250716	CLFS2000251016
20	3.0	50	7/10	16	CLFS2000300716	CLFS2000301016
25	1.0	50	7/10	16	CLFS2500100716	CLFS2500101016
25	1.5	50	7/10	16	CLFS2500150716	CLFS2500151016
25	2.0	50	7/10	16	CLFS2500200716	CLFS2500201016
25	3.0	50	7/10	16	CLFS2500300716	CLFS2500301016
30	1.0	50	7/10	16	CLFS3000100716	CLFS3000101016
30	1.5	50	7/10	16	CLFS3000150716	CLFS3000151016
30	2.0	50	7/10	16	CLFS3000200716	CLFS3000201016
30	2.5	50	7/10	16	CLFS3000250716	CLFS3000251016
30	3.0	50	7/10	16	CLFS3000300716	CLFS3000301016